



Russell Hobbs

INSTRUCTIONS AND WARRANTY



MODEL NO. RHPT04

RUSSELL HOBBS VELORA 2 SLICE TOASTER

1-year standard warranty

Warranty will be extended another year if you register your product
online within 12 months of purchase

(visit <https://russellhobbswarranty.co.za/>)



Congratulations for purchasing our Russell Hobbs Velora 2-Slice Toaster. Each Russell Hobbs appliance is manufactured to ensure safety and reliability. Before using this appliance for the first time please read the following instruction manual carefully and keep it for future reference.

FEATURES OF THE RUSSELL HOBBS VELORA 2-SLICE TOASTER

- 2 Slice toaster
- Premium textured plastic finish
- Adjustable browning control with 6 heat settings
- Bread centering
- Cancel, reheat & defrost functions
- Lift & look feature
- Removable crumb tray
- Integrated cord storage
- 1050W
- For domestic use only
- 1-year standard warranty. Warranty will be extended for another year if you register your product online within 12 months of purchase (visit <https://www.russellhobbs.co.za>)

PARTS DIAGRAM

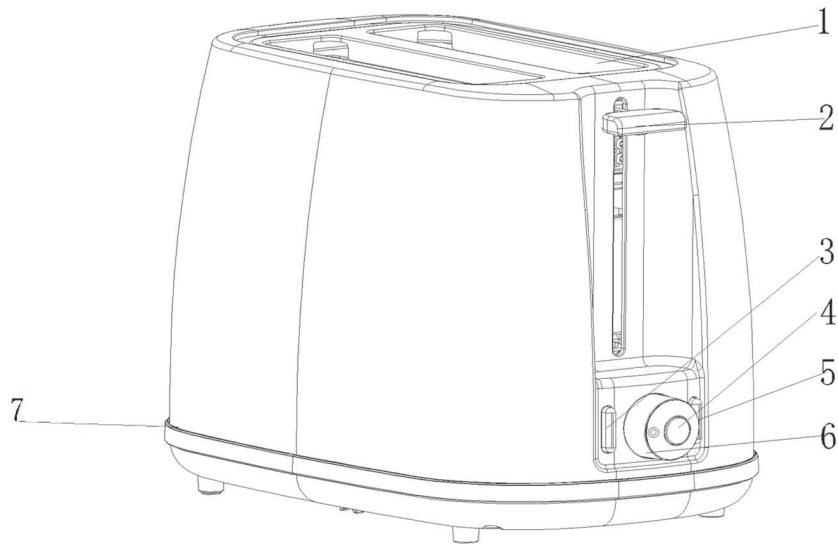

1	Toaster slots
2	Loading Lever
3	Reheat button
4	Cancel button
5	Frozen button
6	Browning control dial
7	Removable crumb tray

IMPORTANT SAFEGUARDS

In order to avoid damage to this appliance or injury to the user, the following list of basic safety measures should always be adhered to. If the user fails to comply with these measures the warranty will become invalid, and the supplier cannot be held responsible.

1. This appliance is intended for household use only.
2. This appliance should be kept out of reach from children unless supervised.
3. This appliance is not intended for use by persons with reduced physical, sensory or mental capabilities unless they are supervised during use or given instructions concerning the use of this appliance by a person responsible for their safety.

4. Always ensure that the indicated voltage on the packaging corresponds to the mains voltage in your home.
5. Position the appliance and the power cord on a flat, even and stable surface.
6. Do not position the appliance near anything flammable.
7. Ensure that the power cord is not in a position where it can be pulled on inadvertently.
8. Check the power cord and plug regularly for any damage.
9. Ensure that the appliance is switched off and unplugged while it is not in use or before cleaning it. To remove the plug from the socket the power supply needs to be switched off, then grip and pull out the plug. Do not pull on the power cord.
10. Do not carry the appliance by the power cord.
11. Use of an extension cord with this appliance is not recommended. If it is however necessary to make use of an extension cord, ensure that the cord is suited to the power consumption of the appliance and the cord is not in a position where it can be pulled on inadvertently.
12. Do not insert any objects into holes or slots in this appliance.
13. Do not immerse or expose the motor assembly, plug or the power cord to water.
14. Never cover the toaster slots while in use.
15. When using a single toasting slot, be cautious of the other slot as both sides heat up simultaneously.
16. Don't let anything enter the toasting slots other than bread, as you might damage the internal heating elements.
17. Do not try to toast "battered" bread or make toasted sandwiches in the toaster.
18. Do not use torn, curled up or broken slices of bread as they may get jammed in the slots. If this happens unplug the toaster from the wall socket, let it cool down fully and then carefully attempt to remove the bread. Do not make use of anything sharp to remove the bread as you may damage the internal heating elements.
19. Do not operate the toaster unless the crumb tray is closed and securely attached.
20. Clean the crumbs out of your toaster frequently. A build-up of crumbs is unhygienic and could cause a fire hazard.
21. Do not make use of accessory attachments or spare parts that are not recommended or supplied by the manufacturer.
22. This appliance must not be operated by an external timer or remote-control system.

23. In the case of a technical problem, switch off the appliance and do not attempt to repair it yourself. Return the appliance to the supplier or an authorised service facility for assessment and/or repair.
24. The supplier does not accept responsibility for any damage or injury caused by incorrect use or for repairs carried out by unauthorised personnel.

OPERATING INSTRUCTIONS

Carefully remove your toaster from its packaging. Keep this packaging in the case of a warranty claim.

Preparation before first use

To ensure that any residues left over from the manufacturing process are removed you'll need to operate your toaster without any bread in it. Start by turning the browning control to the highest setting (7), press the loading lever down fully and wait for the toasting cycle to complete. Ensure the room is well ventilated as this process may give off a smell which is normal.

Toasting bread

1. Position the toaster and the power cord on a flat, even and stable heat resistant surface.
2. Do not position the appliance near anything flammable.
3. Plug the power cord into the wall socket.
4. Place one or two slices of bread into the toasting slots
5. Turn the browning control to the desired setting (1 = light, 6 = dark)
6. Press the loading lever down fully. The lever will only lock down into place if the main power supply at the wall socket is switched on.
7. Once the toasting process has completed, the toast will pop up and the heating elements inside the toaster will automatically turn off.

Note: Do not attempt to toast buttered bread or sandwiches in this toaster.

Eject/ cancelling

To stop the toaster before the toasting cycle is complete you can press the cancel button. The toast will pop up and the heating elements will turn off automatically.

Defrost bread

This feature enables you to toast frozen bread.

1. Leave the browning control at your preferred setting (1 = light, 6 = dark).
2. Put the frozen bread into the slots.
3. Press the loading lever down fully until it locks down into place.
4. Press the defrost button which will light up to indicate that it is switched on.
5. Your toaster will extend the toasting time to allow the bread to defrost.
6. Once the toasting process has completed, the toast will pop up and the heating elements inside the toaster will automatically turn off.

Reheating toast

The reheat button allows you to warm your toast without further browning or burning it.

1. Reduce the browning control to a lower heat setting (1 = light, 6 = dark).
2. Put the toast into the slots.
3. Press the loading lever down fully until it locks down into place.
4. Press the reheat button which will light up to indicate that it is switched on.
5. Once the heating process has completed, the heated toast will pop up and the heating elements inside the toaster will automatically turn off.

CLEANING AND MAINTENANCE

General

- Ensure that the toaster is unplugged from the main power supply before cleaning it.
- To remove external spots or marks wipe the toaster surface with a cloth which is slightly dampened in warm soapy water or a mild non-abrasive cleaner.
- Don't let anything enter the toasting slots other than bread, as you might damage the internal heating elements.
- Do not use harsh or abrasive cleaning agents or solvents to clean your toaster.

Cleaning the crumb tray

Clean the crumbs out of your toaster frequently to avoid a build-up of crumbs which can be unhygienic and hazardous.

1. Unplug the toaster and allow it to cool down.
2. Remove the crumb tray.
3. Wipe the crumb tray with a damp cloth, dry and then reattach it to the toaster.

4. Do not operate the toaster unless the crumb tray is closed and securely attached.

Storing the appliance

- Unplug the appliance from the electrical outlet and clean the parts as instructed above.
- Ensure that all parts are clean and dry before storing.
- The underside on the toaster provides a wraparound cord storage space.
- Store the appliance in its original packaging or in a clean, dry place.

Servicing the appliance

There are no serviceable parts in this appliance which the user is required to service.

Changing the plug

If necessary, the fitted plug can be changed provided the wires in this mains lead are connected accordance with the below colour code diagram. The plug needs to correspond with the current indicated on the packaging.

WARNING: If your appliance has three wires (Green/Yellow, Blue, Brown) then it **MUST** be earthed. Connect a three pin plug as shown below

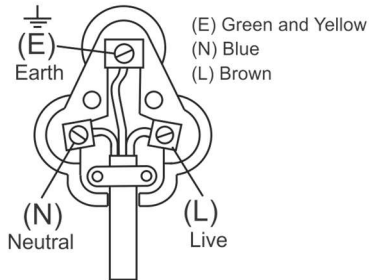

If your appliance has only two wires (Blue, Brown) then it does not need to be earthed. Connect a three pin plug as shown below

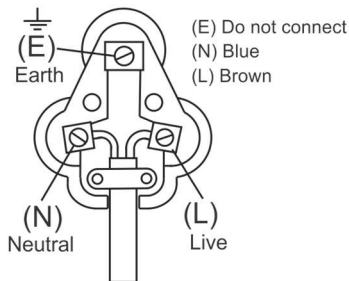

RETURNS & WARRANTY

If the appliance is not operating correctly, please conduct the following checks:

- That the unit has been correctly, and securely plugged into the wall socket.
- That the correct wall socket has been switched on.
- That the main power supply is ON.
- You have read the instruction manual.

If the appliance still does not work after conducting the above checks and you are still within the warranty period, please consult the retailer from which you purchased your appliance for a possible replacement. If the retailer fails to resolve this issue you may contact the supplier, Home of Living Brands (Pty) Limited, for further assistance.

**PLEASE AFFIX YOUR PROOF OF PURCHASE/RECEIPT HERE
IN THE EVENT OF A CLAIM UNDER WARRANTY THIS RECEIPT MUST BE PRODUCED.**

1 YEAR WARRANTY

1-year standard warranty. Warranty will be extended for another year if you register your product online within 12 months of purchase (visit <https://www.russellhobbs.co.za>)

W A R R A N T Y AND EXTENDED WARRANTY

1. Home of Living Brands (Pty) Limited ("Home of Living Brands") warrants to the original purchaser of this product ("the customer") that this product will be free of defects in quality and workmanship which under normal personal, family or household use and purpose may manifest within a period of 1 (one) year from the date of purchase ("warranty period").
2. Home of Living Brands shall extend the warranty period for a further period of 1(one) year ("extended warranty period*"), on condition that the purchaser registers the product on the website, within 12 months from the date of purchase of the product. The website address for registration: <https://russellhobbswarranty.co.za/>
3. Where the customer has purchased a product and it breaks, is defective or does not work properly for the intended purpose, the customer must notify the supplier from whom the customer bought the product ("the supplier") thereof within the warranty period or if applicable, the extended warranty period. Any claim in terms of this warranty must be supported by a proof of purchase. If proof of purchase is not available, then repair, and/or service charges may be payable by the customer to the supplier.
4. The faulty product must be taken to the supplier's service centre to exercise the warranty.
5. The supplier will refund, repair or exchange the product in terms of this warranty subject to legislative requirements. This warranty shall be valid only where (a) the customer is not the cause of the product breaking, and (b) the product has been used for the intended purpose stipulated in the product manual. The warranty does not include and will not be construed to cover products damaged as a result of disaster, misuse, tamper, abuse or any unauthorised modification or repair of the product.
6. This warranty will extend only to the product provided at the date of the purchase and not to any expendables attached or installed by the customer. In this regard any accessories supplied with the product by the supplier, may be excluded in this warranty or extended warranty (see Exclusions to Warranty and Extended Warranty document).
7. If the customer requests that the supplier repairs the product and the product breaks or fails to work properly within 3 (three) months of the repair and not as a result of misuse, tampering or modification by or on behalf of the customer, then the supplier may replace the product or pay a refund to the customer, subject to the supplier's discretion.
8. The customer may be responsible for certain costs where products returned are not in the original packaging, or if the packaging is damaged. This will be deducted from any refund paid to the customer.

HOME OF LIVING BRANDS (PTY) LTD (JOHANNESBURG)

NATIONAL CONTACT

www.homeoflivingbrands.com
www.russellhobbs.co.za
www.facebook.com/RussellHobbsSA

TEL NO. (087) 245-0029

EXCLUSIONS TO WARRANTY AND EXTENDED WARRANTY

1. Any accessories supplied with the product, including but not limited to, bowls, jugs, mills, or carafes made either of glass or plastic and supplied with this appliance (hereinafter referred to as “the accessory or accessories”), is warranted to be free from material and workmanship defects for the duration of the appliance warranty.
2. The accessories should give trouble free service when used in accordance with the directions described in the instruction manual. However, the accessories will be damaged if subjected to impact, and this damage is not covered by the warranty. Such impact damage can occur either from the outside (if for example it is dropped or knocked against a hard surface), or from within (if for example foreign objects are placed within the accessories and the power is switched on).
3. Should you need to replace an accessory during the warranty period; a claim for a free replacement will only be considered if the item (including all shards and broken parts) is returned to the nearest HOLB service centre for examination.
4. The remains of the accessory will be carefully examined by the relevant professionals and if it is determined (at the sole discretion of HOLB) that the damage was caused by impact, then the claim will be refused and will not be covered by the warranty or any extended warranty.
5. Any replacement part provided in terms of clause 4 above will become a chargeable item payable by the customer.